

INSTALLATION INSTRUCTIONS

29772

1992 – 2000 Chevy P.U. C/K Series, Crew Cab

Parts List:

QTY
 P01 (1) Sidebar set
 (Driver & Passenger)
 P02 (2) Front mounting brackets
 P03 (2) Rear mounting brackets

(1) Hardware kit including:
 T01 (4) 1/2 x 1 1/2" Hex head bolt
 T02 (4) M12 x 120mm Hex head bolt
 T03 (8) 1/2" Flat washer
 T04 (8) 1/2" Lock washer

Tools required:

3/4" Socket Ratchet
 18mm Socket 19mm Socket

Instructions:

Aproximated installation time: 30 min.

1. Read and understand instructions completely before beginning installation.
2. Sidebar set consist of a driver and passenger side. Be sure to determine the correct side before installation.
3. Remove the four applicable body mounting bolts from the vehicle. These bolts are not reused in this installation. The body steel washer plates and rubber cushions are reused between the body mount and the sidebar mounting brackets.
4. Position de mounting brackets up under the body mounts. Install M12 x 120mm hex head bolt, 1/2" flat and lock washers through the hole in the mounting bracket and the body mounting washer plate and rubber cushion as shown.
5. Place the sidebar up to the mounting brackets and bolt to the mounting brackets using the 1/2 x 1 1/2" hex head bolt, flat and lock washer. Leave loose.
6. Make any final adjustments to the alignment of the sidebar and tighten all bolts. Repeat for the opposite side.
7. You may need to periodically re-tighten the bolts.

Assembly Diagram:

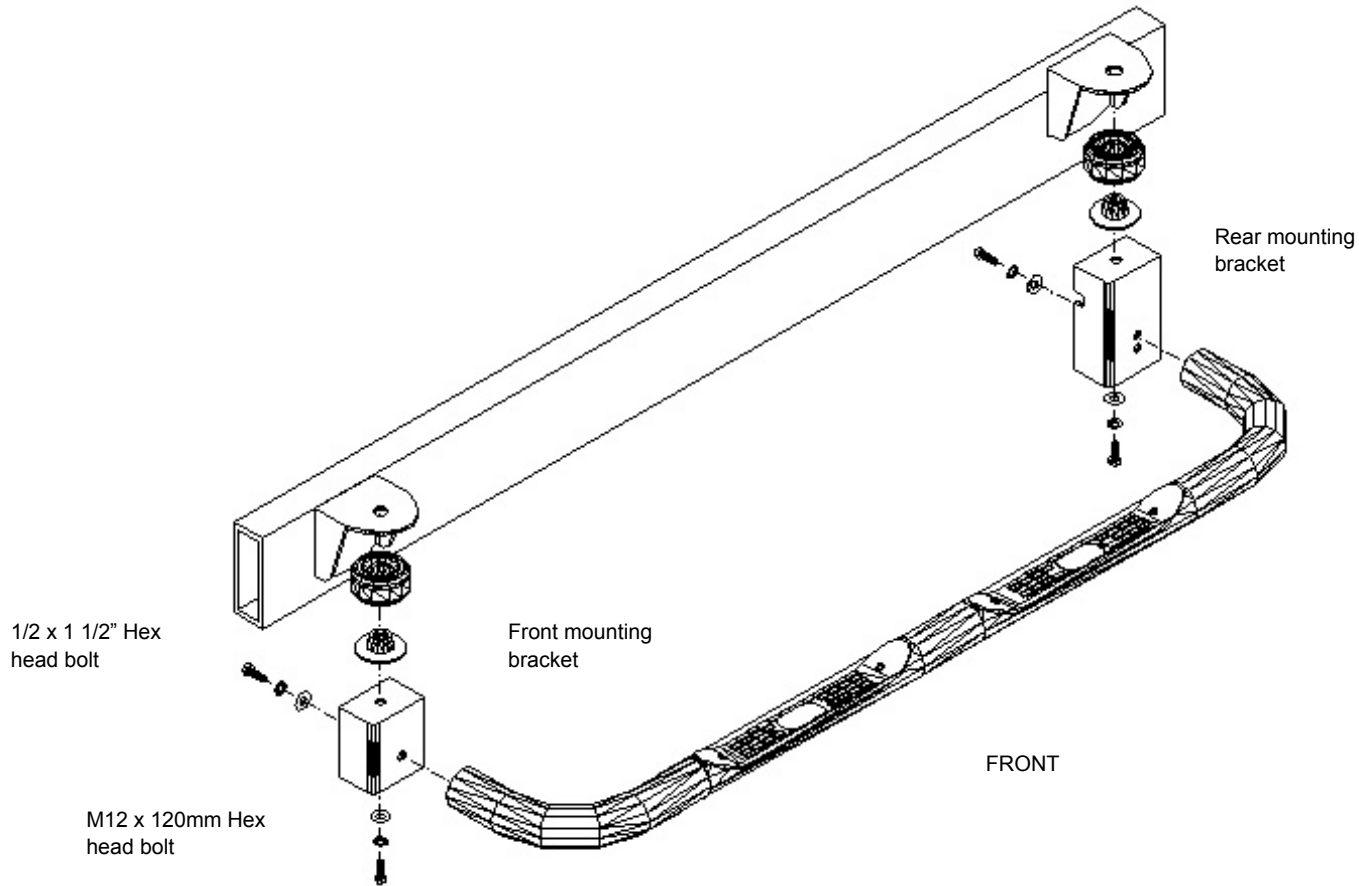

Cleaning and care instructions:

Protect the finish with a non-abrasive automotive wax, (e.g. Pure Carnauba) on a regular basis. The use of any soap, polish, or wax that contains an abrasive is detrimental to the finish, as the compounds scratch the finish and cause corrosion.