

**Big Tex Grille Guard**  
 Installation Instructions  
**77608 & 77608B**  
 Toyota Tundra '07 - '08

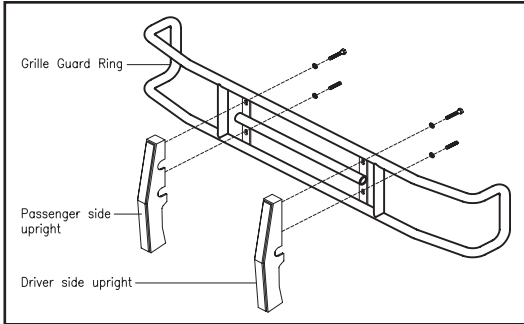

**Diagram 1**

**Parts list:**

1 - Grille Guard Ring	4 - 1/2" x 4" HH Bolt
1 - Driver Side Upright	8 - 1/2" x 1 1/4" HH Bolt
1 - Passenger Side Upright	8 - 1/2" Lock Washers
2 - Bottom Bracket #608-7	8 - 1/2" Hex Nuts
2 - Top Bracket #46608-5	16 - 1/2" Flat Washers
2 - Top Side Bracket #46608-9	

1. Remove the contents from the box and check for missing pieces or damage. If parts are missing or damaged, contact the original place of purchase. Read the instructions completely before beginning. Two people are strongly recommended for this install.

2. **Assemble the Grille Guard Ring and Uprights:** See **Diagram 1**, assemble the Uprights to the Grille Guard Ring. Each upright will get (2) - 1/2" x 1 1/4" hex head bolts and (2) - 1/2" flat washers that will go through the vertical plate on Grille Guard ring into upright. Hand tighten all bolts at this time.

**View of Driver Side Top of The Frame**

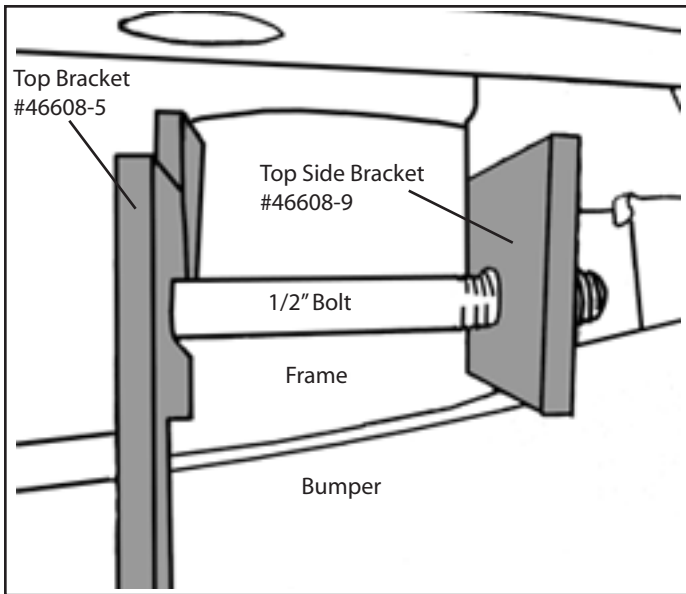

**Diagram 2**

**View of Driver Top Bracket #77608-5 Through The Bumper**

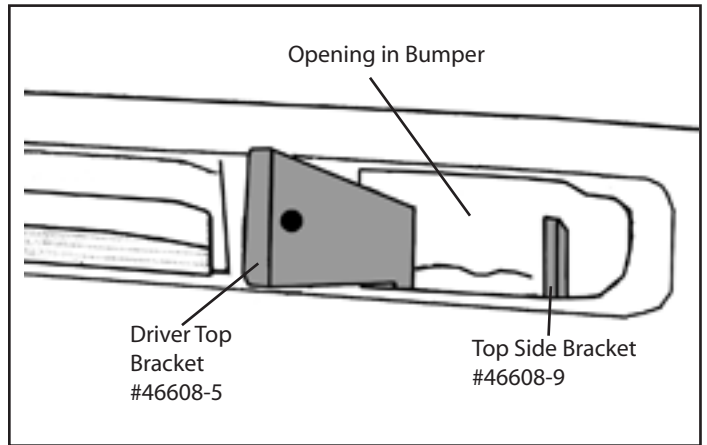

**Diagram 3**

3. **Install the Driver Top Bracket #46608-5 and Driver Side Bracket #46608-9:** As shown in **Diagram 2**, place driver top bracket #46608-5 through opening in bumper. Turn driver top bracket #46608-5 on the side and place driver top bracket to the inside of the frame. Place a (1) 1/2" x 4" HH bolt through driver top bracket #46608-5 into driver side bracket #46608-9. Put a (1) 1/2" flat washer, (1) 1/2" lock washer and (1) 1/2" hex nut onto 1/2" bolt in the top and bottom hole. Hand tighten at this time.

A. Repeat the procedure above to install Passenger Top Bracket #46608-5 and Passenger side bracket #46608-9.

420 N. Grove, Richardson, TX 75081  
Tele: (800) 527 - 4345 Fax: (800) 442 - 5263  
Web site: [www.goindustries.com](http://www.goindustries.com)  
E-mail: [sales@goindustries.com](mailto:sales@goindustries.com)

4. **Install the Bottom Bracket #608-7:** Using **Diagram 4**, remove the 2 bolts holding the tow hook. Place driver bottom bracket #608-7 to the bottom of the frame. Replace tow hook with the factory bolts going through driver bottom bracket #608-7 and into frame. Hand tighten at this time.

A. Repeat above procedure for the passenger bottom bracket #608-7 .

5. **Attach the Grille Guard to the mounting brackets:** Using two people align the Grille Guard holes to the top brackets. Attach the Grille to the top brackets using (2) 1/2" x 2" hex head bolts, (2) 1/2" flat washers, per hole in upright. Hand tighten all bolts at this time.

6. **Center the Grille Guard on the vehicle:** Center the Grille Guard on the vehicle. Tighten all bolts at this time insuring the Grille Guard remains centered on vehicle.

7. **Finish protection:** Go Industries have a high quality finish that must be cared for periodically ( every 30 days ), like any other exposed finish on the vehicle. Protect the finish with a non-abrasive automotive wax (pure carnuba) on a regular basis. The use of cleaner wax or any compound that contains an abrasives detrimental as the compound will scratch the finish and open it to corrosion.

**View of Tow Hook**

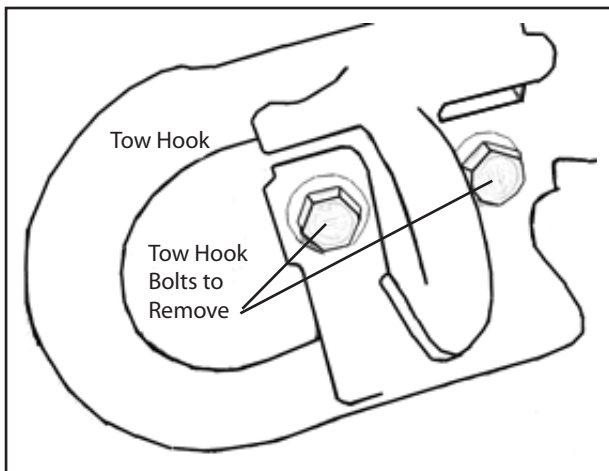

**Diagram 4**

**View of Bottom Bracket #608-7 Attached**

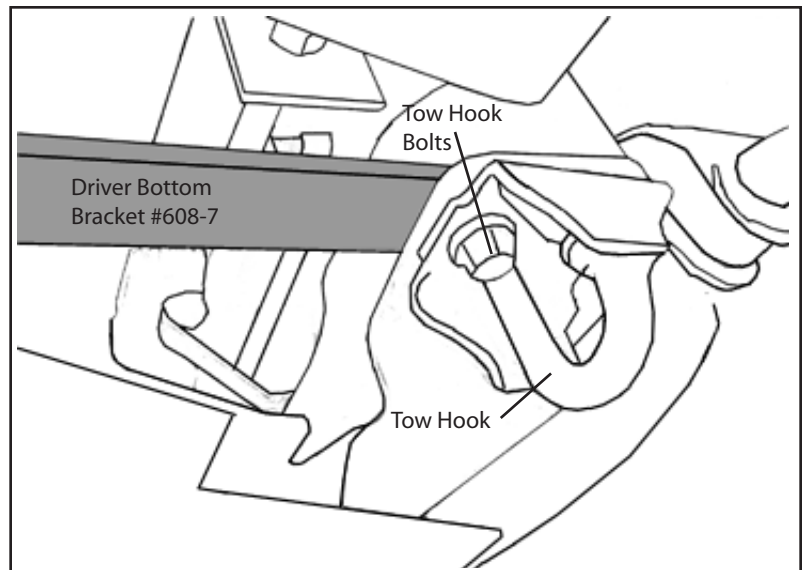

**Diagram 5**