

420 N. Grove, Richardson, TX 75081
 Tele: (800) 527 - 4345 Fax: (800) 442 - 5263
 Web site: www.goindustries.com
 E-mail: sales@goindustries.com

Big Tex Grille Guard

Installation Instructions

77610 & 77610B

Ford Super Duty '08 - '09

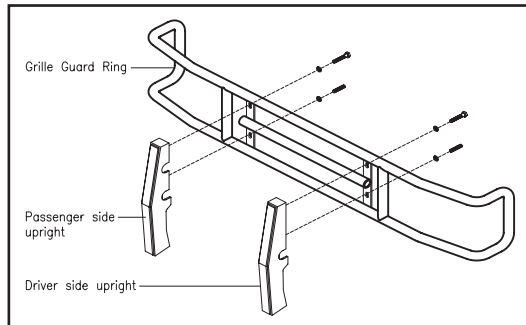

Diagram 1

Parts List:

| | |
|---------------------------------|----------------------------|
| 1 - Grille Guard Ring | 4 - 1/2" x 1 1/4" HH Bolts |
| 1 - Driver Side Upright | 4 - 1/2" x 2" HH Bolts |
| 1 - Passenger Side Upright | 6 - 1/2" x 1 1/2" HH Bolts |
| 1 - Driver Rear bracket #420 | 10 - 1/2" Hex Nuts |
| 1 - Passenger Rear Bracket #429 | 14 - 1/2" Lock Washers |
| 1 - Top Driver Brace #642-7 | 18 - 1/2" Flat Washers |
| 1 - Top Passenger Brace #642-8 | |
| 2 - Main Brackets #642-5 | |

1. Remove the contents from the box and check for missing pieces or damage. If parts are missing or damaged, contact the original place of purchase. Read the instructions completely before beginning. Two people are strongly recommended for this install.

2. **Assemble the Grille Guard Ring and Uprights:** See **Diagram 1**, assemble the Uprights to the Grille Guard Ring. Each upright will get (2) - 1/2" x 1 1/4" hex head bolts and (2) - 1/2" flat washers that will go through the vertical plate on Grille Guard ring into upright. Hand tighten all bolts at this time.

3. **Install Main Brackets #642-5 and Rear Brackets #420 and #429:** Remove the bumper bolts on the driver side and set aside. The OE bumper bolts will not be reused. The bumper bolts are located outside the tow hooks.

A. See **Diagram 2:** Place the driver rear bracket #420 up to the back of the bumper and line up the 2 holes with the bumper bolt holes. Locate the hole in the frame that lines up with the driver rear bracket #420. Place (1) 1/2" flat washer on (1) 1/2" x 1 1/2" HH bolt and insert through the frame and into the driver rear bracket #420. Place (1) 1/2" flat washer, (1) 1/2" lock washer and (1) 1/2" hex nut on the bolt and hand tighten at this time.

B. See **Diagram 3:** Place the front bracket #642-5 up to bumper bolt holes. Place (1) 1/2" flat washer on (1) 1/2" x 2" HH bolt and insert through the front bracket #642-5, through the bumper holes and into the driver rear bracket #420. Place (1) 1/2" flat washer, (1) 1/2" lock washer and (1) 1/2" hex nut on the (1) 1/2" x 2" HH bolt and hand tighten at this time.

Repeat this process for the passenger side rear bracket #429 and main bracket #642-5.

View Behind Bumper Bracket #420 Driver Side

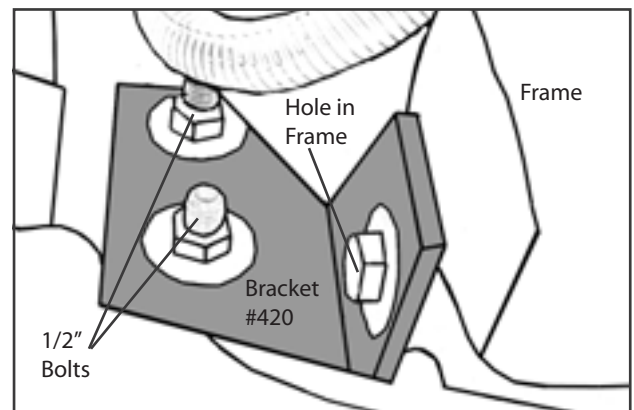

Diagram 2

View of Driver Side Bumper

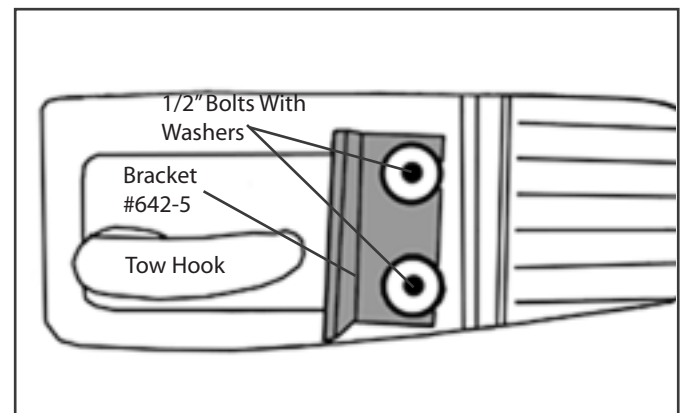

Diagram 3



77610 & 77610B

420 N. Grove, Richardson, TX 75081
Tele: (800) 527 - 4345 Fax: (800) 442 - 5263
Web site: www.goindustries.com
E-mail: sales@goindustries.com

5. **Attach the Grille Guard to the main brackets #642-5:** Using two people align the Grille Guard holes to the front brackets #642-5. Attach the Grille Guard to brackets using (2) - 1/2" x 1 1/2" hex head bolts, (2) - 1/2" flat washers, (2) - 1/2" lock washers and (2) - 1/2" hex nuts per side and hand tighten the nuts. Place (1) 1/2" x 1 1/2" HH bolts, (1) 1/2" flat washers into the top brace and the second hole on the upright. Hand tighten the bolts at this time. Tighten the factory bolt on the top brace, then the 1/2" x 1 1/2" HH bolt into the upright. Tighten the rear braces and the main brackets next. Tighten the (4) 1/2" x 1 1/2" HH bolts, (8) 1/2" flat washers, (4) 1/2" lock washers and (4) 1/2" hex nuts next making sure the grille guard is level. When tightening make sure the upright is pulled out at the bottom. This will insure the grille guard stays level on the sides.

6. **Finish protection:** Go Industries have a high quality finish that must be cared for periodically (every 30 days), like any other exposed finish on the vehicle. Protect the finish with a non-abrasive automotive wax (pure carnuba) on a regular basis. The use of cleaner wax or any compound that contains an abrasives detrimental as the compound will scratch the finish and open it to corrosion.