

420 N. Grove, Richardson, TX 75081
 Tele: (800) 527 - 4345 Fax: (800) 442 - 5263
 Web site: www.goindustries.com
 E-mail: sales@goindustries.com

Big Tex Grille Guard

Installation Instructions

77611 - 77611B

Dodge Ram '06 - '09 2500/3500 - with or w/o tow hooks

Dodge Ram '06 - '08 1500 - with or w/o tow hooks

Will not fit trucks with sport or Laramie bumper

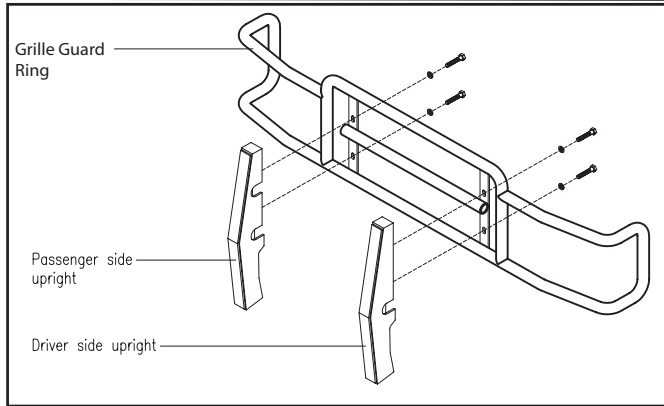

Diagram 1

Parts List:

1 - Grille Guard Ring	2 - 1/2" Lock Washers
1 - Driver Side Upright	2 - 1/2" x 1" Carriage bolts
1 - Passenger Side Upright	4 - 1/2" Hex Nuts
1 - Driver Top Bracket #77663-5	4 - 1/2" x 1 1/2" HH Bolts
1 - Passenger Top Bracket #77663-6	4 - 1/2" x 1 1/4" HH Bolts
2 - Bottom Bracket #663-7 & 8	10 - 1/2" Flat Washers
2 - Bottom Bracket #663-9	

1. Before installation check **Diagram 2** and make sure your bumper looks like the example. If your bumper looks different from **Diagram 2**, you may have the wrong part.

2. Remove the contents from the box and check for missing pieces or damage. If parts are missing or damaged, contact the original place of purchase. Read the instructions completely before beginning. Two people are strongly recommended for this install.

3. **Assemble the Grille Guard Ring and Uprights:** See **Diagram 1**, assemble the Uprights to the Grille Guard Ring. Each upright will get (2) - 1/2" x 1 1/4" hex head bolts and (2) - 1/2" flat washers that will go through the vertical plate on Grille Guard ring into upright. Hand tighten all bolts at this time.

4. **Install the Driver Top Bracket #77663-5 and Passenger Top Bracket #77663-6:** Open the hood on the truck. Using **Diagram 3**, locate the bumper bolt on each side of the vehicle. Remove the nut from the bolt. Locate the Driver and Passenger Top Brackets, #77663-5 and #77663-6.

A. Place Driver Top Bracket #77663-5 onto bumper bolt. The end of the Driver Top Bracket #77663-5 (**Diagram 4**) with the 90 degree bend should go onto bumper bolt. Replace nut and hand tighten at this time.

B. Repeat step "A" above on the passenger side to install Passenger Top Bracket #77663-6.

5. **1500 Installation of the Bottom Bracket #663 -7 & #663-8:** Using **Diagram 5**, remove the 1/2" bolt from "B". Slide bottom bracket #663-7 up till it centers on upper hole on bottom bracket #663-8. Replace 1/2" bolt, 1/2" nut and 1/2" lock washer into upper hole. Bracket should look like "A" in **Diagram 5**. Do not tighten. Using **Diagram 6**, locate the factory frame bolt on the vehicle. Remove the factory nut from the factory frame bolt. Place bottom bracket #663-7 onto the factory frame bolt. Re-place the factory nut over the bottom bracket #663-7. Do not tighten.

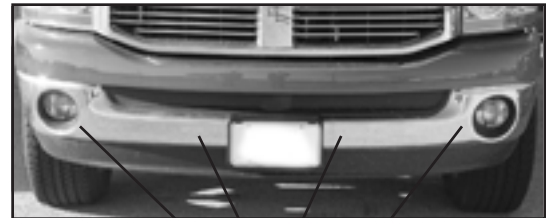

Diagram 2

View Behind Bumper (Driver Side)

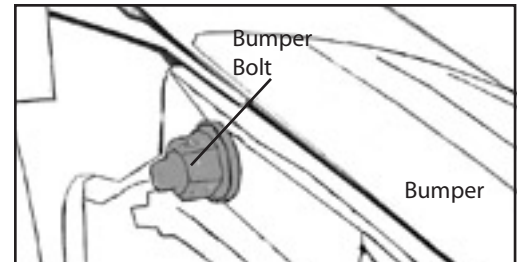

Diagram 3

Driver Top Bracket #77663-5 Installed

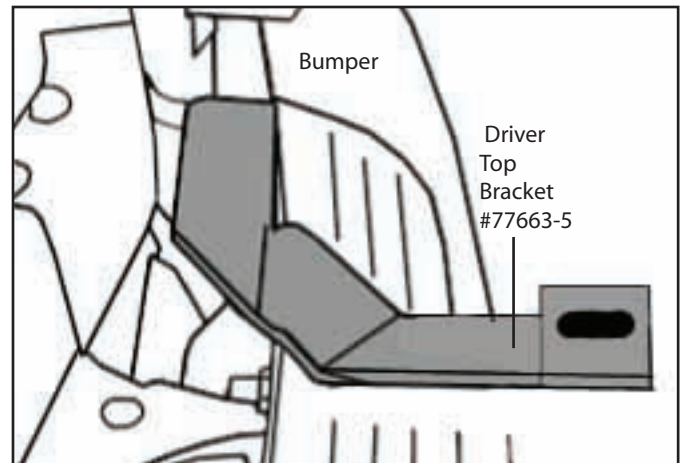

Diagram 4

420 N. Grove, Richardson, TX 75081
 Tele: (800) 527 - 4345 Fax: (800) 442 - 5263
 Web site: www.goindustries.com
 E-mail: sales@goindustries.com

77611 & 77611B

View of Bracket #663-7 and #663-8

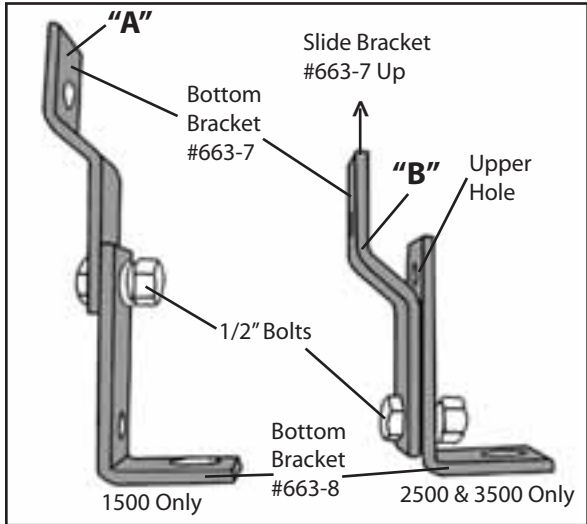

Diagram 5

6. **2500/3500 Installation of the Bottom Bracket #663-7 & #663-8:** The bracket #663-7 & #663-8 is in kit the way it needs to be installed. Do not remove the 1/2" bolt on the 2500 & 3500 vehicles. Using **Diagram 6**, locate the bumper bolt. Remove the nut from the bumper bolt and place bottom bracket #663-7 & #663-8 up to bumper bolt then replace nut. Do not tighten.

7. **Install the Bottom Bracket #663-9:** Using **Diagram 7**, attach bottom bracket #663-9 to bottom bracket #663-7 & 8. Use the 1/2" x 1 1/4" HH bolt in kit to attach bottom bracket #663-9 to bottom bracket #663-7 & #663-8 with a 1/2" flat washer, 1/2" lock washer and a 1/2" hex nut. Do not tighten.

8. **Attach the Grille Guard to the mounting brackets:** Using two people align the Grille Guard holes to the top brackets. Attach the (**Diagram 8**) Grille Guard to the top brackets #77663-5, #77663-6 using (1) 1/2" x 1" carriage bolt with (1) 1/2" lock washer and (1) 1/2" hex nut. Bottom brackets #663-9 using (1) 1/2" x 1 1/2" hex head bolts, (1) 1/2" flat washers, per hole in upright. Hand tighten all bolts at this time.

9. **Center the Grille Guard on the vehicle:** Center the Grille Guard on the vehicle. Tighten all bolts at this time insuring the Grille Guard remains centered on vehicle.

7. **Finish protection:** Go Industries have a high quality finish that must be cared for periodically (every 30 days), like any other exposed finish on the vehicle. Protect the finish with a non-abrasive automotive wax (pure carnuba) on a regular basis. The use of cleaner wax or any compound that contains an abrasives detrimental as the compound will scratch the finish and open it to corrosion.

View Behind Bumper with Frame Bolt

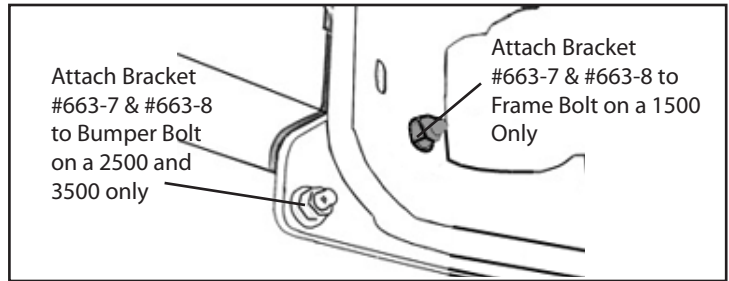

Diagram 6

View of Bottom Bracket #663-9

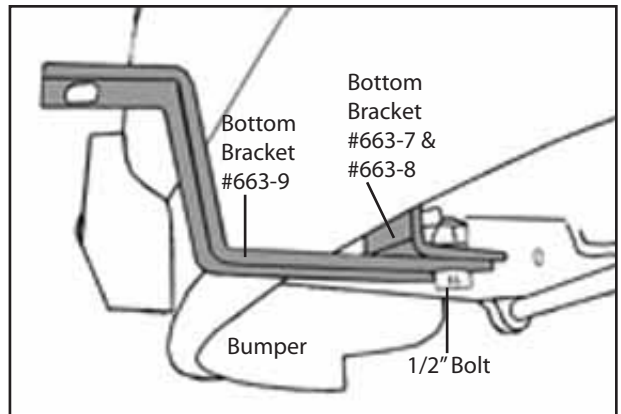

Diagram 7

View of Driver Top Bracket #77663-5

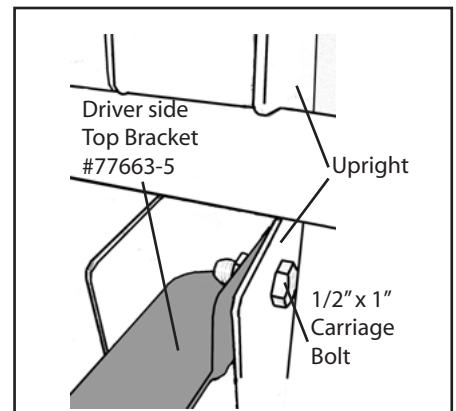

Diagram 8

Caution:

Lower hood carefully, make sure there is clearance for the hood to close. Damage could occur if hood is closed onto Grille Guard. Note: Grille Guard can be adjusted for clearance by loosening top and bottom bracket. Push bottom of grille guard in and tighten bottom bracket first, then top bracket.