

420 N. Grove, Richardson, TX 75081  
 Tele: (800) 527 - 4345 Fax: (800) 442 - 5263  
 Web site: www.goindustries.com  
 E-mail: sales@goindustries.com

**Big Tex Grille Guard**  
 Installation Instructions  
**77633 & 77633B**  
 Ford F-150 w/o tow hooks '99 - '03  
 Ford F-150 Heritage w/o tow hooks '04

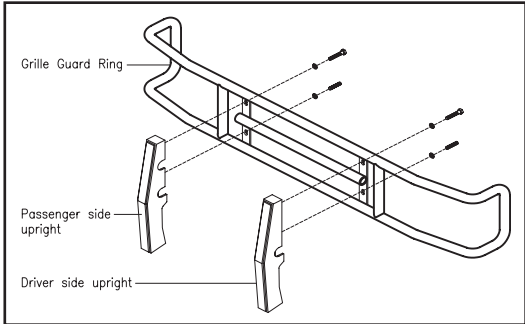

**Diagram 1**

<b>Parts List:</b>	
1 - Grille Guard Ring	2 - 3/8" x 2 1/2" All-Thread Studs
1 - Driver Side Upright	2 - 3/8" Hex Nuts
1 - Passenger Side Upright	2 - 3/8" Lock Washers
1 - Driver Top Bracket #634-5	2 - 1/2" x 4 1/2" HH Bolts
1 - Passenger Top Bracket #634-6	2 - 1/2" Hex Nuts
1 - Driver Bottom Bracket #633-7	4 - 12mm Jam Nuts
1 - Passenger Bottom Bracket #633-8	6 - 1/2" x 1" HH Bolts
	8 - 1/2" Lock Washers
	10 - 1/2" Flat Washers

1. Remove the contents from the box and check for missing pieces or damage. If parts are missing or damaged, contact the original place of purchase. Read the instructions completely before beginning. Two people are strongly recommended for this install.

2. **Assemble the Grille Guard Ring and Uprights:** See **Diagram 1**, assemble the Uprights to the Grille Guard Ring. Each upright will get (2) - 1/2" x 1 1/4" hex head bolts and (2) - 1/2" flat washers that will go through the vertical plate on Grille Guard ring into upright. Place the (2) - 3/8" x 2 1/2" all thread studs into the third welded plate from the top of the upright. Make sure the 3/8" x 2 1/2" all thread stud is showing past the bottom of the welded plate in the upright. Hand tighten all bolts at this time.

3. **Install the Driver Top Brackets #634-5 and Passenger Top Bracket #634-6:** Using **Diagram 2**, insert the driver top bracket #634-5 between the bumper and the grille of the truck, starting at the outside edge of the bumper and fender. Behind the bumper at the bumper frame mount there is a rubber shield, pull this free from the frame by removing the plastic rivet. This will allow proper placement of the top bracket. Position the top bracket at the center of frame. Place bracket over exposed ends of the factory bolts. Attach with (2) - 12mm jam nuts supplied, leaving loose at this time.

A. Repeat above procedure to install the passenger top bracket #634-6.

**View of Frame With Bracket Placement**

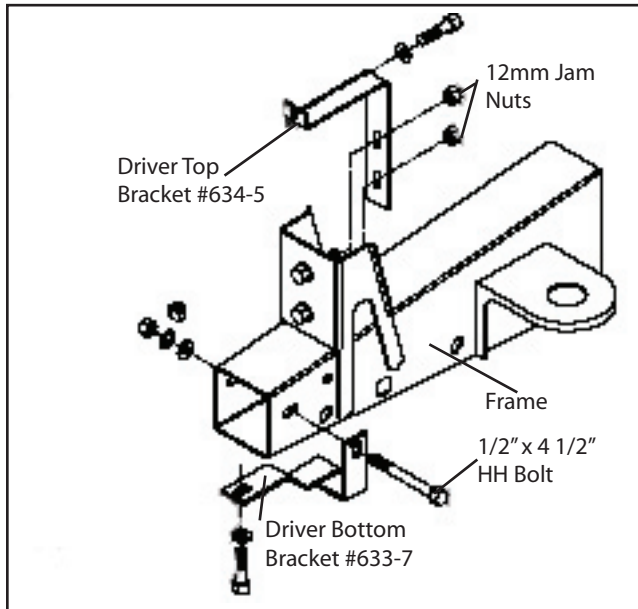

**Diagram 2**

4. **Install the Driver Bottom Bracket #633-7 and Passenger Bottom Bracket #633-8:** Using **Diagram 2**, place bottom bracket #633-7 against down spoiler and mark the spoiler for cut-out. Cut out marked area of spoiler. Place the driver bottom bracket #633-7 against outside of frame. Put a 1/2" flat washer onto a 1/2" x 4 1/2" bolt and put through bracket #633-7 and frame. Place a 1/2" flat washer, 1/2" lock washer and 1/2" hex nut onto the 1/2" x 4 1/2" HH bolt. Hand tighten nut at this time.

B. Repeat above procedure to install the passenger bottom bracket #633-8.

5. **Attach the Grille Guard to the top brackets #634-5 & #634-6 and bottom brackets #633-7 & #633-8:** Using two people align the Grille Guard holes to the top brackets #634-5 & 634-6. Place the (2) - 3/8" x 2 1/2" all thread studs through the top brackets. Place a (2) - 3/8" flat washer and (2) - 3/8" hex nuts onto (2) - 3/8" x 2 1/2" all thread studs. Place (2) - 1/2" flat washer onto (2) - 1/2" x 1" HH bolt put through bottom brackets #633-7 & #633-8 into the upright. Hand tighten the nuts and bolts at this time.

6. **Center the Grille Guard on the vehicle:** Center the Grille Guard on the vehicle. Tighten all bolts at this time insuring the Grille Guard remains centered on vehicle.