

420 N. Grove, Richardson, TX 75081  
 Tele: (800) 527 - 4345 Fax: (800) 442 - 5263  
 Web site: www.goindustries.com  
 E-mail: sales@goindustries.com

## Big Tex Grille Guard

Installation Instructions

### 77636 & 77636B

Ford F-150 '04 - '05

Note: Does not fit '04 Heritage

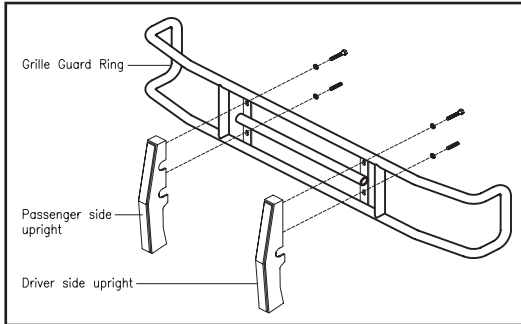

**Diagram 1**

#### **Parts list:**

1 - Grille Guard Ring	2 - M10 Flat Washers
1 - Driver Side Upright	2 - M10 x 30 Hex Head Bolts
1 - Passenger Side Upright	4 - 1/2" Lock Washers
1 - Driver Top Bracket #636-5	8 - 1/2" x 1 1/4" HH Bolts
1 - Passenger Top Bracket #636-6	8 - 1/2" Flat Washers
1 - Driver Bottom Bracket #636-7	
1 - Passenger Bottom Bracket #636-8	

1. Remove the contents from the box and check for missing pieces or damage. If parts are missing or damaged, contact the original place of purchase. Read the instructions completely before beginning. Two people are strongly recommended for this install.

2. **Assemble the Grille Guard Ring and Uprights:** See **Diagram 1**, assemble the Uprights to the Grille Guard Ring. Each upright will get (2) - 1/2" x 1 1/4" hex head bolts and (2) - 1/2" flat washers that will go through the vertical plate on Grille Guard ring into upright. Hand tighten all bolts at this time.

#### **Top View of Driver Top Bracket #636-5 Installed**

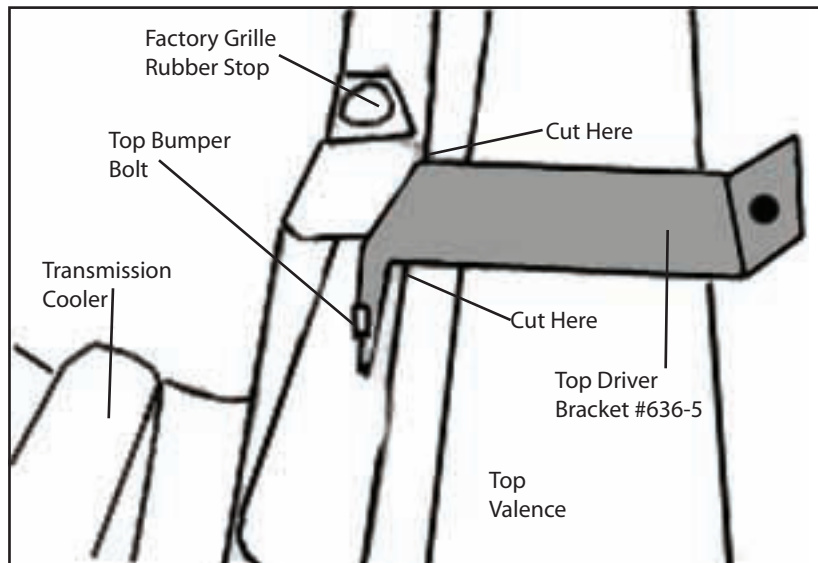
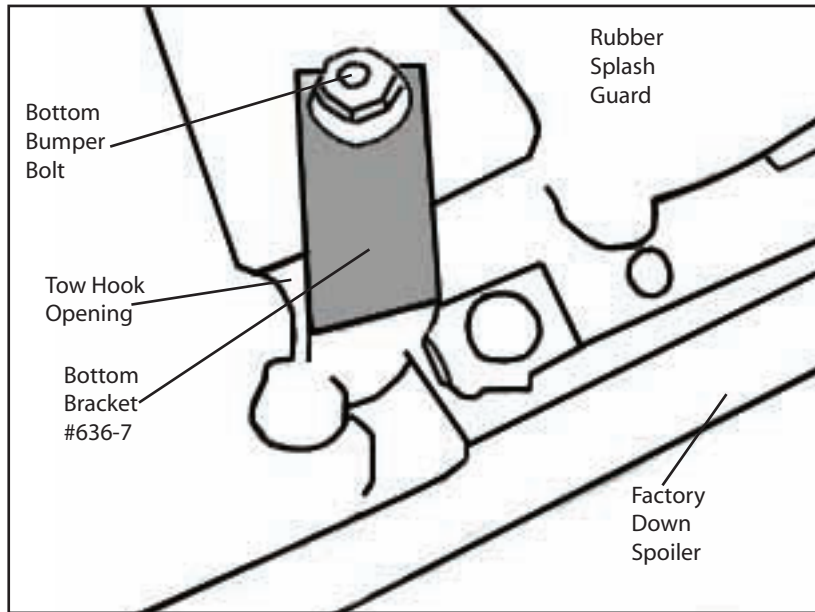

**Diagram 2**

3. **Install the Driver Top Bracket #636-5:** Open the hood on the vehicle. Using **Diagram 2**, locate the top bumper bolt. Remove factory bumper bolt and discard bolt. Locate the Driver Top Bracket #636-5, place bracket onto plastic valence lining it up with bolt hole. Use M10 x 30 hex head bolt from kit to attach bracket. Push down on the bracket to insert M10 x 30 hex head bolt and tighten about a 1/4". Make sure bracket is flat against the bolt area then cut top valence down to the crease. This will allow the top valence to remain flat and the bracket to lay flat.

A. Repeat the procedure above to install Passenger Top Bracket #636-6.

**View of Bottom Bumper Bolt & Driver Bottom Bracket #636-7**



**Diagram 3**

4. **With Tow Hooks Install Driver Bottom Bracket #636-7:** Using **Diagram 3**, locate bottom bumper bolt. Bolt and nut will be hidden by a rubber splash guard. Move splash guard to the middle of the vehicle to locate bottom bumper bolt. Remove nut, place turned up end of bracket #636-7 to bottom bumper bolt. Bracket will come out of the opening for the tow hook. Replace nut and only hand tighten at this time.

A. Repeat above procedure for Passenger Bottom Bracket #636-8.

5. **Without Tow Hooks Install Driver Bottom Bracket #636-7:** Using **Diagram 3**, locate bottom bumper bolt. Bolt and nut will be hidden by a rubber splash guard. Move splash guard to the middle of the vehicle to locate bottom bumper bolt, remove nut. Take bottom Bracket #636-7 and slide the bracket into opening until it touches the factory down spoiler. Align bracket with bottom bumper bolt. Make sure the bracket is level before marking factory down spoiler to be cut out. Cut out opening to allow bottom bracket #636-7 to pass through. Place turned up end of bracket onto bottom bumper bolt and replace nut. Hand tighten nut at this time.

A. Repeat above procedure for Passenger Bottom Bracket #636-8.

6. **Center the Grille Guard on the vehicle:** Center the Grille Guard on the vehicle. Tighten all bolts at this time insuring the Grille Guard remains centered on vehicle.