

420 N. Grove, Richardson, TX 75081
 Tele: (800) 527 - 4345 Fax: (800) 442 - 5263
 Web site: www.goindustries.com
 E-mail: sales@goindustries.com

Big Tex Grille Guard

Installation Instructions

77660 - 77660B

Dodge Ram '02 - '05 1500 w/o tow hooks
 Dodge Ram '03 - '05 2500/3500 w/o tow hooks

77661 - 77661B

Dodge Ram '03 - '05 2500/3500 with tow hooks

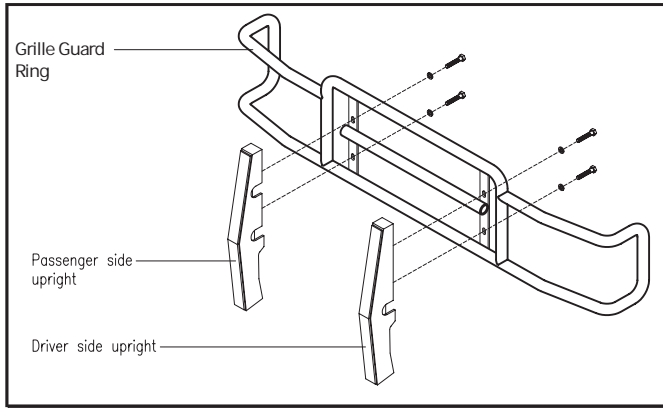

Diagram 1

Parts List

1 - Grille Guard Ring #658	2 - 1/2" x 5 1/2" HH Bolts
1 - Driver Side Upright	2 - 1/2" x 2 3/4" All Thread Studs
1 - Passenger Side Upright	2 - 1/2" Lock Washers
1 - Driver Top Bracket #615	2 - 1/2" Hex Nuts
1 - Passenger Top Bracket #616	6 - 1/2" x 1 1/4" HH Bolts
2 - Bottom Brackets #660-7	10 - 1/2" Flat Washers
2 - Metal Spacers	

Note: Will not fit the Ram Sport or Rams with plastic bumper covers

1. Remove the contents from the box and check for missing pieces or damage. If parts are missing or damaged, contact the original place of purchase. Read the instructions completely before beginning. Two people are strongly recommended for this install.

2. **Assemble the Grille Guard Ring and Uprights:** See Diagram 1, assemble the Uprights to the Grille Guard Ring. Each upright will get (2) - 1/2" x 1 1/4" hex head bolts and (2) - 1/2" flat washers that will go through the vertical plate on Grille Guard ring into upright. Hand tighten all bolts at this time.

View Behind Bumper (Driver Side)

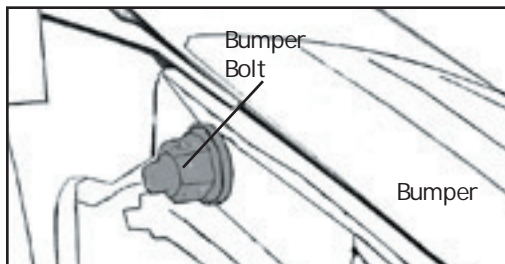

Diagram 2

Driver Top Bracket #615 Installed

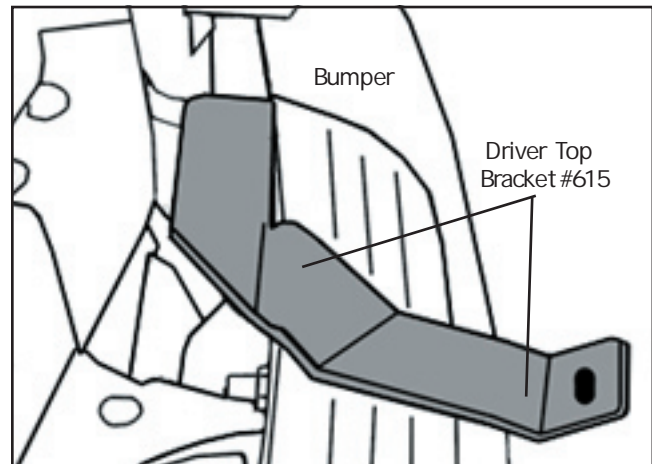

Diagram 3

3. **Install the Driver Top Bracket #615 and Passenger Top Bracket #616:** Open the hood on the truck. Using Diagram 2, locate the bumper bolt on each side of the vehicle. Remove the factory nut from the bolt. Locate the Driver and Passenger Top Brackets, #615 and #616.

A. Place Driver Top Bracket #615 onto the bumper bolt (Refer to Diagram 3). The end of the Driver Top Bracket #615 with the 90 degree bend will go onto the bumper bolt. Replace the factory nut and hand tighten at this time.

B. Repeat step "A" above on the passenger side to install the passenger Top Bracket #616.

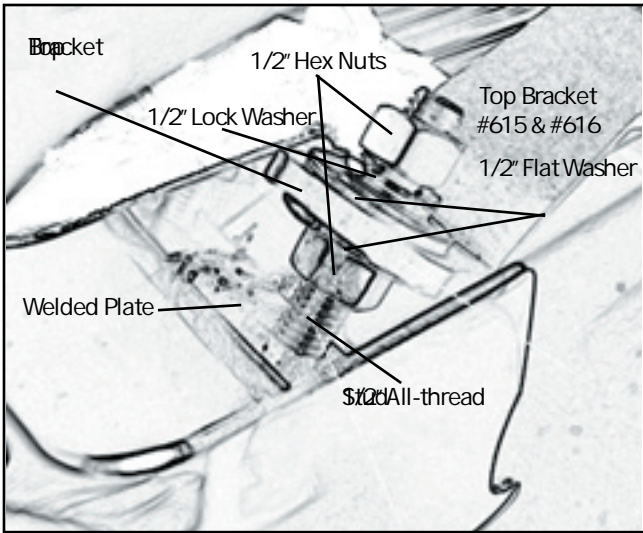

Diagram 4

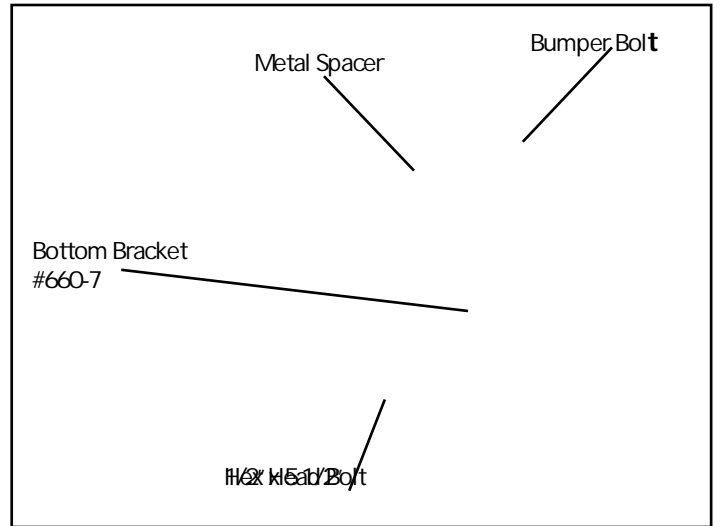

Diagram 5

Caution:

Do not touch the grille guard while it is hot. The grille guard will be very hot after use. Do not touch the grille guard until it has cooled down. Do not touch the grille guard until it has cooled down.