

**Big Tex Grille Guard**  
 Installation Instructions  
**77748 & 77748B**  
 GMC 2500HD & 3500 (New Body) '07 - '08

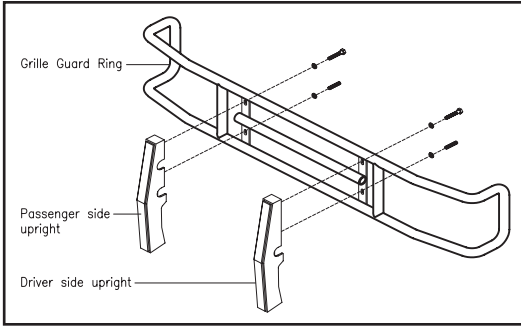

**Diagram 1**

**Parts List:**

- |                                    |                            |
|------------------------------------|----------------------------|
| 1 - Grille Guard Ring #735         | 2 - 1/2" x 1 1/2" HH Bolts |
| 1 - Driver Side Upright            | 6 - 1/2" x 2" HH Bolts     |
| 1 - Passenger Side Upright         | 8 - 1/2" Flat Washers      |
| 1 - Driver Top Bracket #77748-5    |                            |
| 1 - Passenger Top Bracket #77748-6 |                            |
| 2 - Bottom Brackets #738-7         |                            |

**Note: If your vehicle is not equipped with tow hooks, please call (800) 527-4345 for additional parts.**

1. Remove the contents from the box and check for missing pieces or damage. If parts are missing or damaged, contact the original place of purchase. Read the instructions completely before beginning. Two people are strongly recommended for this install.
2. **Assemble the Grille Guard Ring and Uprights:** Using **Diagram 1**, assemble the Uprights to the Grille Guard Ring using (4) 1/2" x 1 1/2" hex head bolts and (4) 1/2" washers. Hand tighten all bolts at this time.
3. **Remove the Factory Radiator Cover:** Open the hood on the truck. Using **Diagram 2**, locate the factory radiator cover. To remove the pop rivets, use a flat head screwdriver to pull up on the middle of the pop rivets. To remove the bottom part of pop rivet, place the screwdriver under the bottom and push up. Repeat this procedure to remove all pop rivets. Do not remove factory grille.

**View of Factory Grille and Radiator Cover**

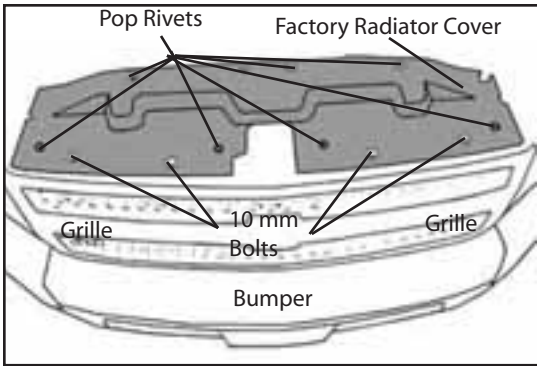

**Diagram 2**

**Rear View of Top Driver Bracket #77748-5**

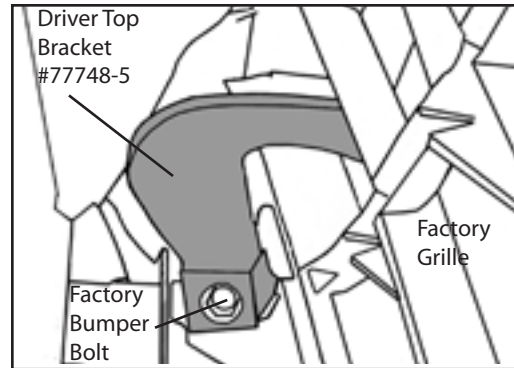

**Diagram 3**

**Front View of Top Driver Bracket #77748-5**

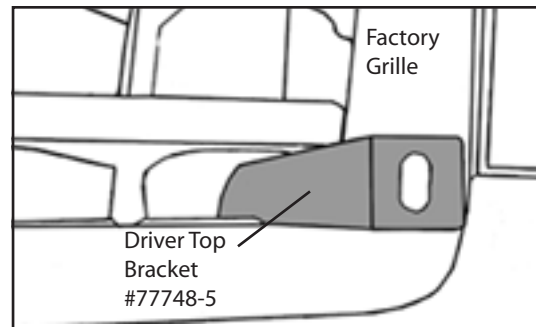

**Diagram 4**

4. **Install the Driver Top Bracket #77748-5 and Passenger Top Bracket #77748-6:** Locate the Top Driver Bracket for installation at this time.

A. Remove the factory bumper bolt as shown in **Diagram 3**. Slide driver top bracket #77748-5 through factory grille as shown in **Diagram 4**. Place the Driver Top Bracket over the opening. Replace the factory bumper bolt through the top bracket and into the bolt hole opening. Hand tighten this bolt at this time.

B. Repeat step "A" above to install the Passenger Top Bracket 77748-6.

**Bottom Bracket #738-7 Front View**

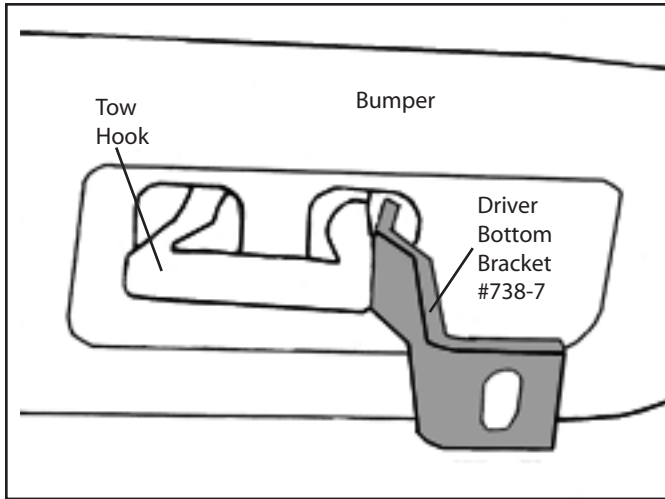

**Diagram 5**

**Bottom Bracket #738-7 Behind Bumper**

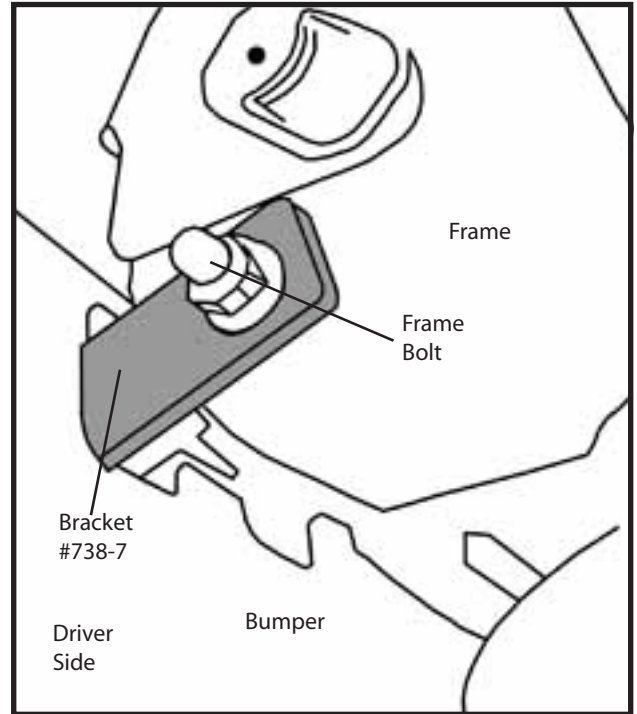

**Diagram 6**

5. **Install the Bottom Brackets #738-7:** Locate the Bottom Brackets #738-7 for installation at this time.

A. **Vehicles with tow hooks:** Using Diagram 5, attach Driver Bottom Bracket #738-7. If the vehicle is equipped with tow hooks, locate the bolt on tow hook. Loosen the bolt and remove Nut. Place flat end of Bottom Brackets #738-7 through the tow hook opening on the outside up against bolt and replace factory nut. Bracket #738-7 should be on the outside of tow hook, refer to **Diagram 4**. Repeat the procedure for the Passenger Side Bracket #738-7. The tow hook bolt will have to be removed and, the bracket placed onto bolt and, then replace the tow hook bolt. Hand tighten all bolts at this time.

B. **Vehicles without tow hooks, please call (800) 527-4345 for additional parts. When you receive the parts, use the following procedure to install grille guard:** If the vehicle is not equipped with tow hooks, the plastic spoiler must be cut out for the bottom bracket to pass through. Align the bottom bracket with the inside hole on the frame and place bottom bracket against the plastic spoiler and mark the area to be cut. Carefully cut a slot for the bottom bracket to pass through the spoiler to the Grille Guard. Use threaded plate #699-9 to take place of tow hook. Place bracket #699-9 inside the frame and line up the threaded hole in bracket #699-9 with the inside hole of frame. Place bottom bracket #738-7 up to frame use (1) 1/2" x 1 1/4" hex head bolt and attach bottom bracket #738-7 to threaded plate. Hand tighten all bolts at this time.

6. **Re-install Factory Radiator Cover:** Re-install Factory Radiator Cover. Take radiator cover place over holes in vehicle. Replace pop rivets into vehicle.

7. **Attach the Grille Guard to the mounting brackets:** Using two people align the Grille Guard holes to the top brackets. Attach the Grille to the top brackets using (1) 1/2" x 2" hex head bolts, (1) 1/2" flat washers, per hole in upright. Hand tighten all bolts at this time.

8. **Center the Grille Guard on the vehicle:** Center the Grille Guard on the vehicle. Tighten all bolts at this time insuring the Grille Guard remains centered on vehicle.